

## Scavenger Transceiver Module STM 400J

The extremely power saving RF transmitter module **STM 400J** of EnOcean enables the realization of wireless and maintenance free sensors and actuators such as room operating panels, motion sensors or valve actuators for heating control.

Power supply is provided by an external energy harvester, e.g. a small solar cell or a thermal harvester. An energy storage device can be connected externally to bridge periods with no supply from the energy harvester. A voltage limiter avoids damaging of the module when the supply from the energy harvester gets too high. The module provides a user configurable cyclic wake up (every 1, 10 or 100 sec.). After wake up a radio telegram (input data, unique sensor ID, checksum) will be transmitted in case of a change of any digital input value compared to the last sending or in case of a significant change of measured analogue values (different input sensitivities can be selected). In case of no relevant input change a redundant retransmission signal is sent after a user configurable number of wake-ups to announce all current values. In addition a wake up can be triggered externally.

### Features

- 3 A/D converter inputs
- 4 digital inputs
- Configurable wake-up and transmission cycle
- Wake-up via Wake pins
- Voltage limiter
- Threshold detector
- Application notes for calculation of energy budgets and management of external energy storages

### Product variants

- STM 400J: SMD mountable module for use with external antenna

**Type**  
**STM 400J**

**Ordering Code**  
**S3061-D400**

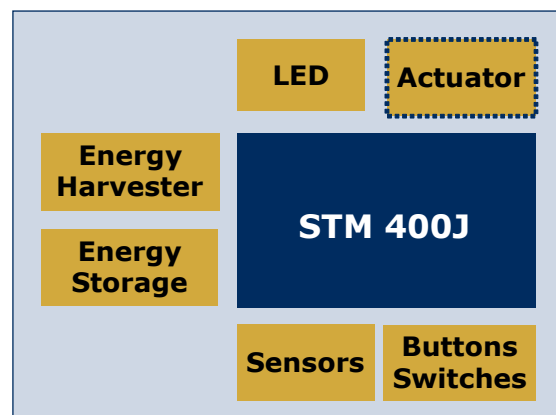

..... With custom firmware

### Energy Harvesting made easy with EnOcean wireless standard

STM 400J is a bidirectional system module for maintenance-free sensor solutions based on the EnOcean wireless standard.

Using the Dolphin API library it is possible to write custom firmware for the module. STM 300/C/U is in-system programmable.

### Features accessible via API:

- Integrated 16MHz 8051 CPU with 64KB FLASH and 4kB SRAM
- Receiver functionality
- Various power down and sleep modes down to 100nA current consumption
- Up to 16 configurable I/Os
- 10bit ADC, 8bit DAC

## EnOcean Dolphin System Architecture. Open. Flexible. Expandable.

The distinguishing feature that sets Dolphin apart from other wireless system architectures is energy harvesting, which enables self-powered wireless sensors and actuators. The Dolphin system architecture joins the components necessary for an energy-autonomous wireless sensor system that operates on a standardized wireless network. These include energy conversion and storage components,

EnOcean wireless modules for energy management, data acquisition, data processing and wireless data transmission, and finally the software blocks operating system, API and application programs.

As an open and expandable hardware and software architecture, Dolphin is future-oriented and fully backward compatible with EnOcean-enabled devices and system components already on the market.

EnOcean modules already have extensive firmware functionality implemented – such as basic switching, dimming and measuring – and can go straight into an application without additional programming. Its built-in application functions enable straightforward start-up and system integration.

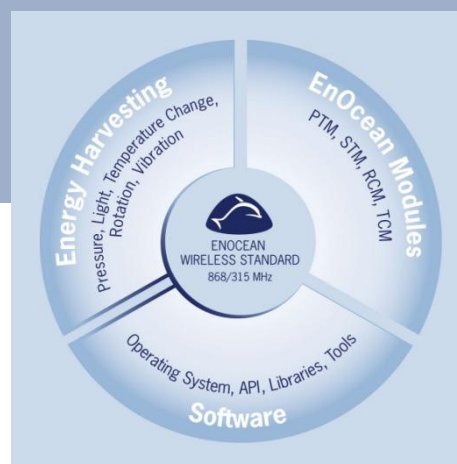

### Benefits for OEM partner

- Maintenance-free sensor solution with energy harvesting
- Ready available and wide-ranging, interoperable system product portfolio
- Fast implementation and time to market
- Low investment in R&D, T&M, etc
- Various evaluation tools obtainable to support development
- EnOcean Development Kit EDK 350 for STM 300
- Technical support
- Competitive advantage over battery-powered wireless solutions
- Participation in EnOcean's eco-system
- EnOcean is the wireless standard for sustainable buildings

### Technical Data

<b>Antenna</b>	External whip or 50 Ω antenna mountable
<b>Frequency</b>	928.35 MHz (FSK)
<b>Data rate</b>	125 kbps
<b>Receiver Sensitivity (at 25°C)</b> only via API	-95 dBm <sup>2)</sup>
<b>Conducted Output Power</b>	0dBm
<b>Power Supply</b>	2.1 V–5.0 V, 2.5 V needed for startup
<b>Current Consumption</b>	Deep Sleep Mode: 100nA Rx mode (API only): 27 mA / Tx mode: 23 mA
<b>Dimensions of PCB</b>	22x19x3 mm
<b>Input Channels</b>	4x digital input, 2x WAKE input, 3x analog input Resolution: 3x 8 bit or 1x 10 bit, 1x 8 bit, 1x 6 bit
<b>Operating temperature</b>	-25 up to +85°C
<b>Radio Regulations</b>	ARIB STD-T108

1) according to ISO/IEC 14543-3-10

2) @ 0.1% telegram error rate (based on transmitted sub-telegrams)